

HM-07C03 HM-07C03/R1 HM-09CA03 HSM-08C03

Mobile type air conditioner Service Manual



Contents

1.PRODUCT CODE ILLUMINATION AND SERIES INTRODUCTION.	1
2.PRRODUCT TECHNICAL PARAMETER.	2
3.PRODUCT SPECIFICATION.	3
4.MAIN COMPONENTS AND ACCESSORIES NAME, DIMENTION AND FUNTION.	4
5.KNOCK-DOWN DRAWING AND LIST OF COMPONENT.	5
6.WIRING DIAGRAM.	6
7.MAINTENANCE ANDTROUBLE SHOOTING.	7
8.SYSTEM FLOW CHART.	8
9.INSTALLATION AND REPAIRING	9
10.SYSTEM FLOW CHART.	10
11.INSTALLATION AND REPAIRING	11

● Features

- High efficiency for saving energy
- Easy to move
- Low noise

Haier Group



Большая библиотека технической документации

<https://splitsystema48.ru/instrukcii-po-ekspluatácii-kondicionerov.html>

каталоги, инструкции, сервисные мануалы, схемы.

Haier

Mobile Type Conditioner Technical Manual

Model: :

HM-07C03, HM-07C03/R1, HM-09CA03, HSM-08C03

CATALOGUE

1、PRODUCT CODE ILLUMINATION AND SERIES INTRODUCTION	1
2、PRRODUCT TECHNICAL PARAMETER	2
3、PRODUCT SPECIFICATION	3
4、MAIN COMPONENTS AND ACCESSORIES'NAME, DIMENTION AND FUNTION.....	4
5、KNOCK-DOWN DRAWING AND LIST OF COMPONENT.....	5
6、MICROCOMPUTER CONTROLING	6
7、THE FUNCTION OF ELECTRIC CONTROL INTRODUCTION	7
8、WIRING DIAGRAM	8
9、MAINTENANCE ANDTROUBLE SHOOTING	9
10、SYSTEM FLOW CHART	10
11、INSTALLATION AND REPAIRING	11

1.RODUCT CODE ILLUMINATION AND SERIES INTRODUCTION

a、 model code rule description

1.1Model identification:

$\underline{H} \underline{S} \underline{M} - \square\square \square \square / \square$
 A B C D E F G H

A:Abbreviation of Haier

B:Abbreviation of Split

C:Abbreviation of Mobile

D:Nominal cooling capacity(BTU/h)with the first two numbers based on one thousand unit

E:Function code

C-Cooling only

H-Heating pump

E-Electric aided heating

F:Developing sequence

G:The type of power supply

H:The kind of refrigerant

Examples:

Hsm-08C03

-It represents Split-Mobile air conditioner.Cooling capacity is 8000 BTUh and the power supply is 200~230V/50Hz.

b、 Standard situation/conditions

No.	Operating condition	Indoor air state		outdoor air state	
		D. B. °C	W. B. °C	D. B. °C	W. B. °C
1	Nominal cooling	30	26	30	26
2	Nominal heating	/	/	/	/
3	Nominal electrical heating	/	/	/	/

C、 Brief introduction of mobile window air conditioner series

The product of mobile air conditioner is the now type of air conditioner developed by our company, its main character is:there are four foot wheels in the bottom of indoor unit, which can move among each apartment of the room. For whole mobileair conditioner such as HM-07C03, HM-07C03/R1, HM-09CA03, hat between indoor unit and outdoor unit can be exchanged through wind pipe, for split-mobile air conditioner such as HSM-08C03, heat can be exchanged through outdoor unit. Drainage of mobile air conditioner use the principle of gravity drainage, having the cooled water flow into water tank, pour it out when the tank is full. This type of product has the advantage of easy installation without breaking the wall, so it is very popular with many consumers.

PRODUCT SPECIFICATIONS

※ The manufacturer reserves the right to change any change any product specifications without notice.

Item	UNIT	HAM-08C03	HM-09CA03
Cooling capacity	BTU/h	8000	900
Heating capacity	BTU/h	/	/
Power supply		1PH,220~50Hz	1PH,220~50Hz
Power factor	%	0.96	0.94
Cooling	Power input	W	880
	Running current	A	4.6
	EER	BTU(hW)	8.6
Heating	Power input	W	/
	Running current	A	/
	COP	BTU(hW)	/
Sund Level	Indoor side	dB(A)	50
	Outdoor side	dB(A)	/
Case	Height	mm	326
	Width	mm	788
	Depth	mm	430
Packaging dimensions	Height	mm	415
	Width	mm	857
	Dpth	mm	495
Weight	Net	kg	33
	Gross	kg	37
Compressor	Type		TOSHIBA
	Model		PH150X1C-4DZ2(2000165)
Pressure	Heating side	MPa	2.65
	Cooling side	MPa	2.65
Refrigerant	Model		R22
	charge	kg	0.75
Fan	Type	indoor unit	inertialfan
		outdoor unit	Axial fan
	Fan speed	Hi	r/min
Lo		r/min	1070
Air direction control		60~70°	60~70°
Air volume Monisture removal	m ³ /hr	260	260
Moisture removal	m ³ /hr	1.6×10 ⁻³	1.6×10 ⁻³
Attestation		CE	CE
Compressor oil charge	ml	400	400
Exchanging pipe type/diameter	mm	evaporator: φ 7condenser: φ 9	evaporator: φ 7condenser: φ 9
Fin factor		/	/
Fin material		Hydrophile aluminum foil	Hydrophile aluminum foil
Case material		Electrial zine board	Electrial zine board
Type of capillary		φ 1.2TP2Y	φ 1.2TP2Y
Total area of evaporator	mm ²	2.02	2.28
Total area of conenser	mm ²	4.67	5.26
Pipe connection		/	/

PRODUCT SPECIFICATIONS

※ The manufacturer reserves the right to change any change any product specifications without notice.

Item	UNIT	HAM-07C03	HM-07C03/R1	
Cooling capacity	BTU/h	7000	7000	
Heating capacity	BTU/h	/	/	
Power supply		1PH,220~50Hz	1PH,220~50Hz	
Cooling	Power input	W	800	
	Running current	A	4.3	
	EER	BTU/(hW)	8.7	
Heating	Power input	W	/	
	Running current	A	/	
	COP	BTU/(hW)	/	
Sund Level	Indoor side	dB(A)	50	
	Outdoor side	dB(A)	/	
Case	Height	mm	326	
	Width	mm	788	
	Depth	mm	430	
Packaging dimensions	Height	mm	415	
	Width	mm	857	
	Dpth	mm	495	
Weight	Net	kg	32	
	Gross	kg	34	
Compressor	Type		TOSHIBA	
	Model		PH135X1C-4DZ2(2000165)	
	Running cap. for comp.	μ F	25	
	Starting method		PSC	
Pressure	Heating side	MPa	2.65	
	Cooling side	MPa	0.65	
Refrigerant	Model		R22	
	charge	kg	0.52	
Fan	Type	indoor unit	inertial fan	
		outdoor unit	/	
	Fan speed	Hi	r/min	1070
		Lo	r/min	1140
Running capacitor	μ F	30	30	
Air direction control		60~70°	60~70°	
Air volume Monisture removal	m ³ /hr	260	260	
Moisture removal	m ³ /hr	1.6×10 ⁻³	1.6×10 ⁻³	
Attestation		CE	CE	
Compressor oil charge	ml	400	400	
Exchanging pipe type/diameter	mm	evaporator: φ 7 冷凝器: φ 9	evaporator: φ 7 冷凝器: φ 9	
Fin factor		/	/	
Fin material		Hydrophile aluminum foil	Hydrophile aluminum foil	
Case material		Electrial zine board	Electrial zine board	
Type of capillary		φ 1.2TP2Y	φ 1.2TP2Y	
Total area of evaporator	mm ²	1.77	1.77	
Total area of conenser	mm ²	4.09	4.09	
Pipe connection		/	/	

3. PRODUCT SPECIFICATION

	HM-07C03	HM-07C03/R1	HM-09CA03	HSM-08C03
Structural faecture	Mobile air conditioner	Mobile air conditioner	Mobile air conditioner	Mobile air conditioner
cooling capacity	7000BTU/h	7000BTU/h	9000BTU/h	8000BTU/h
voltage	220V	220V	220V	220V
Type of product	Mobile air conditioner series	Mobile air conditioner series	Mobile air conditioner series	Mobile air conditioner series
Appeatance feature				
attestation	CE	CE	CE	CE
remote	No	No	No	No
refrigerant	R22	R407C	R22	R22
Climate type	T1	T1	T1	T1
dimensions	430×326×788mm	430×326×788mm	430×326×788mm	430×326×788mm(内机)
packege dimensions	547×499×1147mm	547×499×1147mm	547×499×1147mm	547×499×1147mm(内机)
Box up document	No	No	No	No

4. MAIN COMPONENTS AND ACCESSORIES'NME,DEMENTION AND FUNTION

HM-07C03, HM-07C03/R1, HM-09CA03

MAIN COMPONENTS AND ACCESSORIES

Machine body

Front

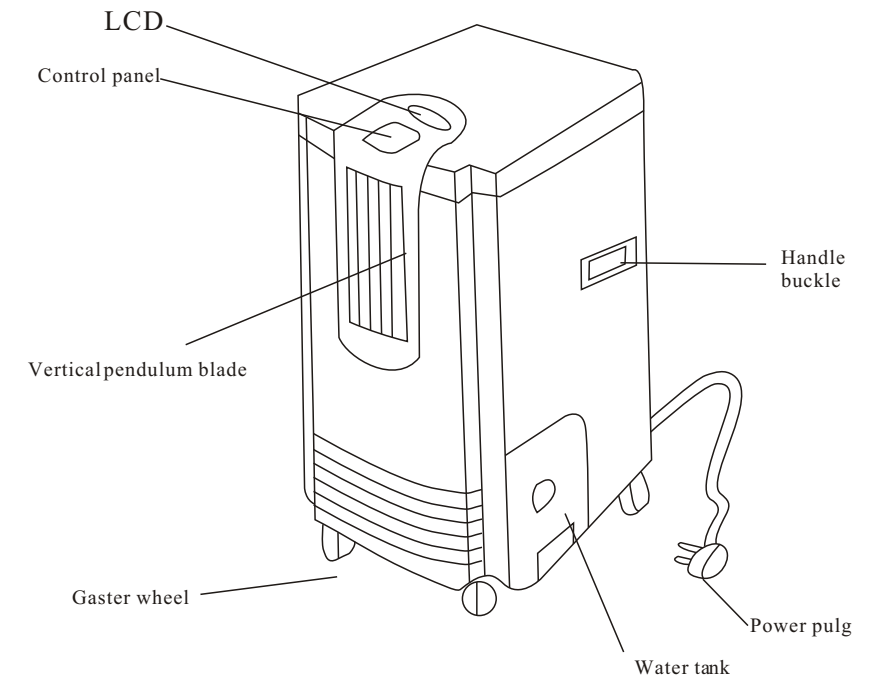

Back

Hot air exhaust duct

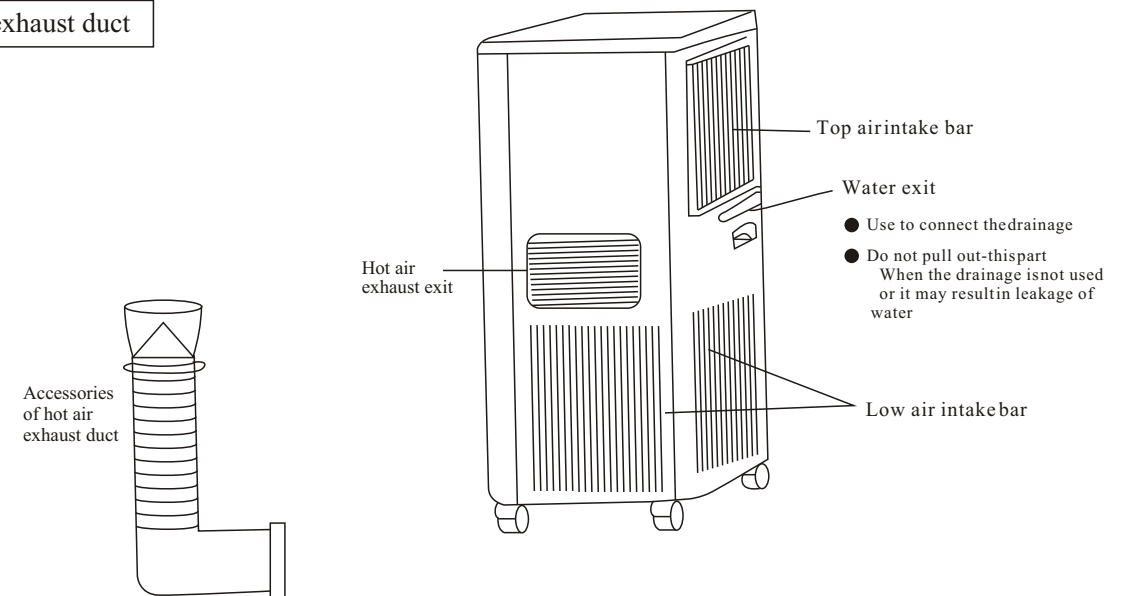

Control panel

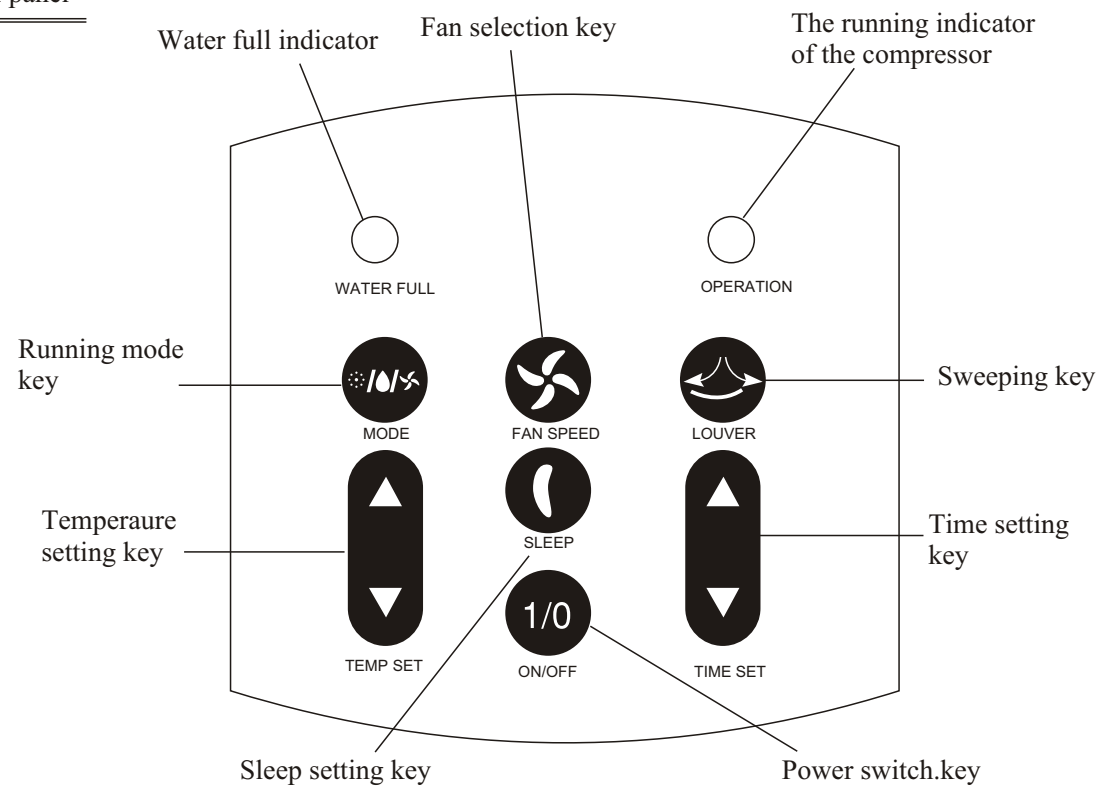

LCD window

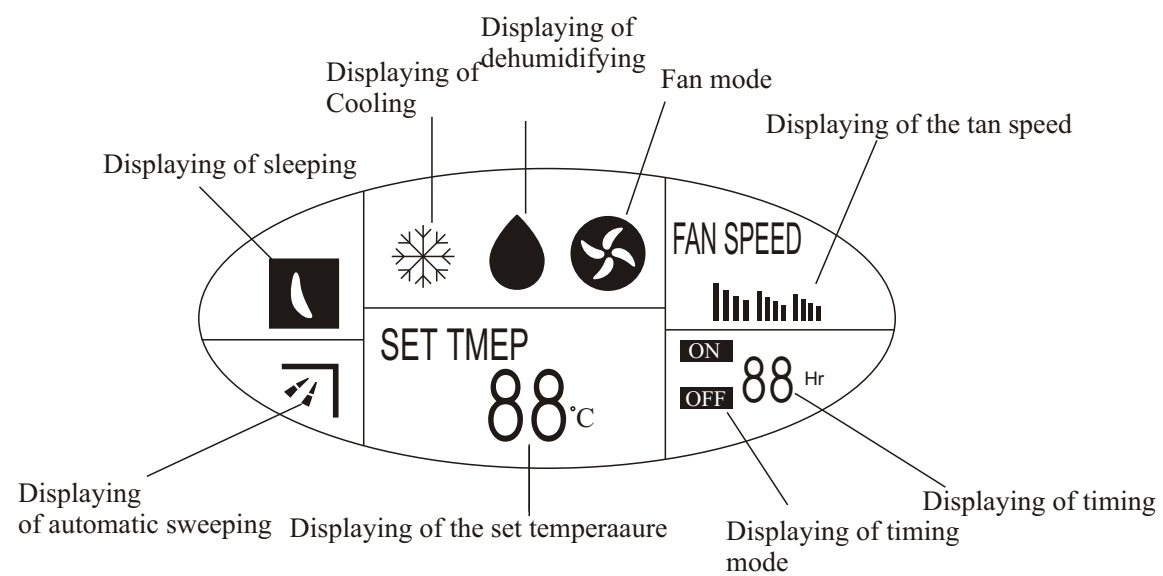

HSM-08C03

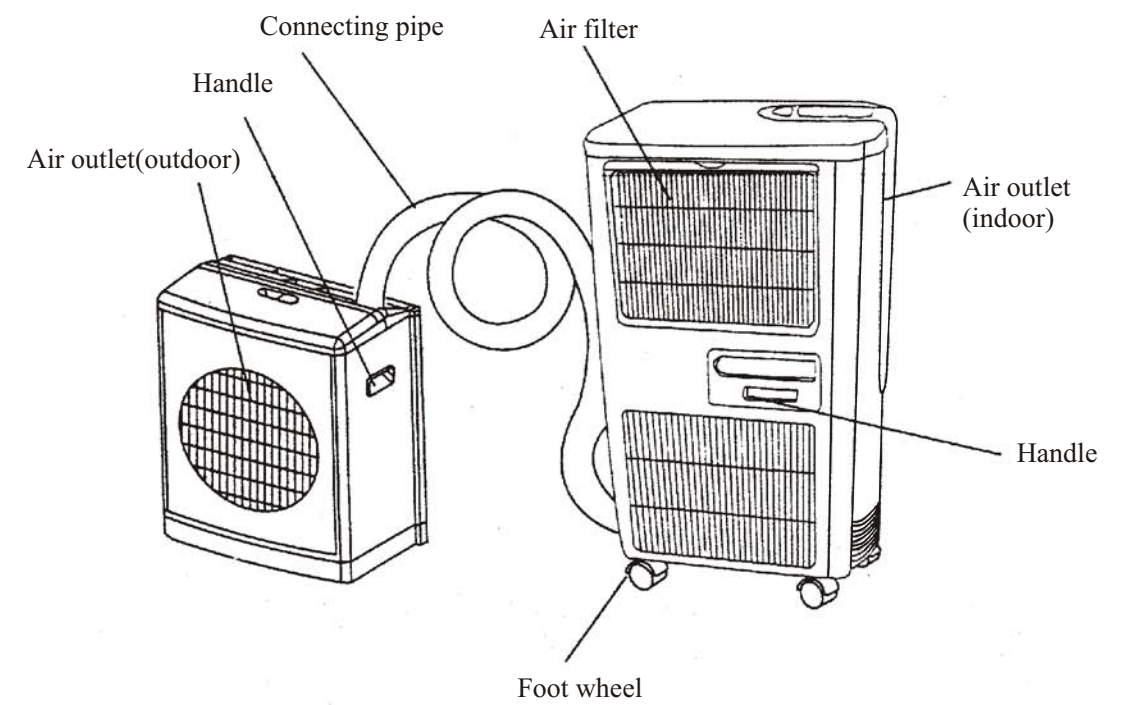
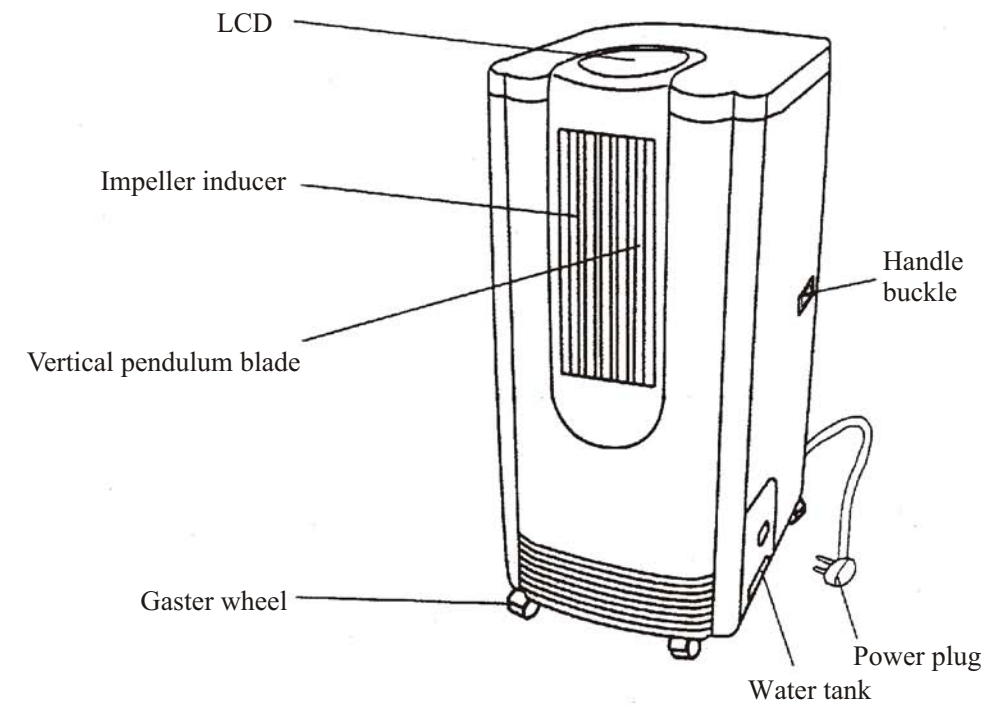

Control panel

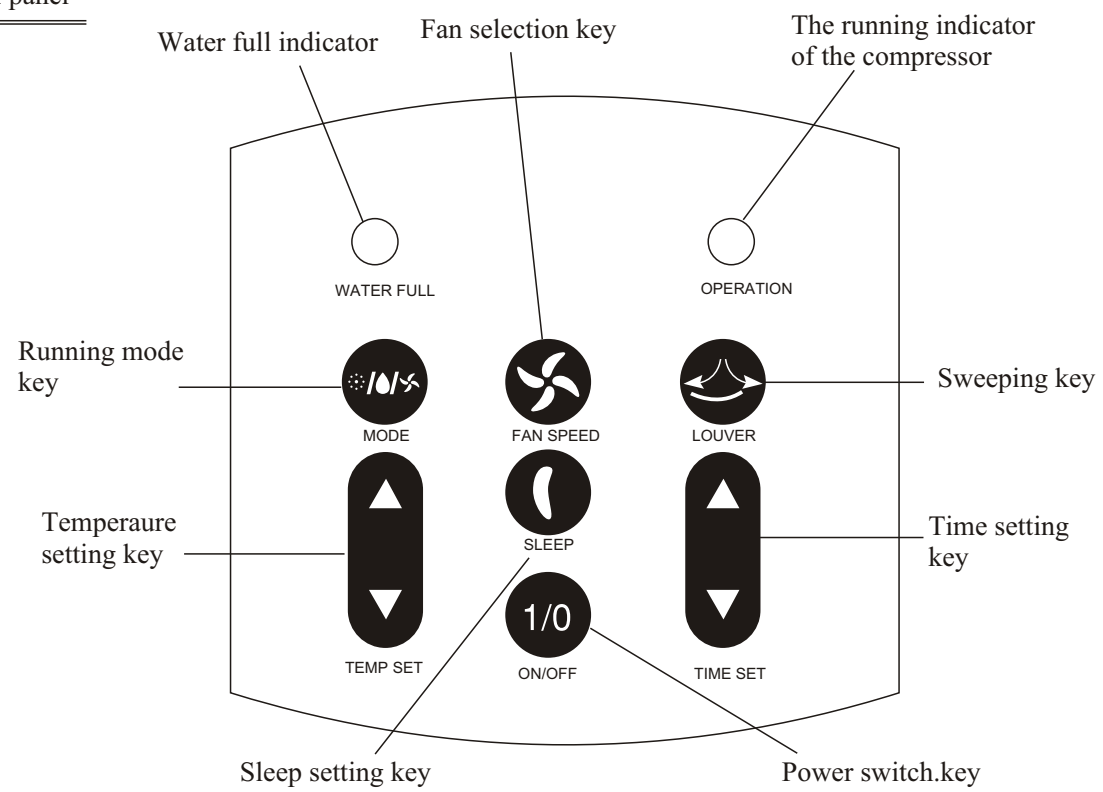

LCD window

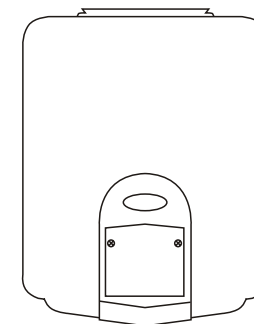
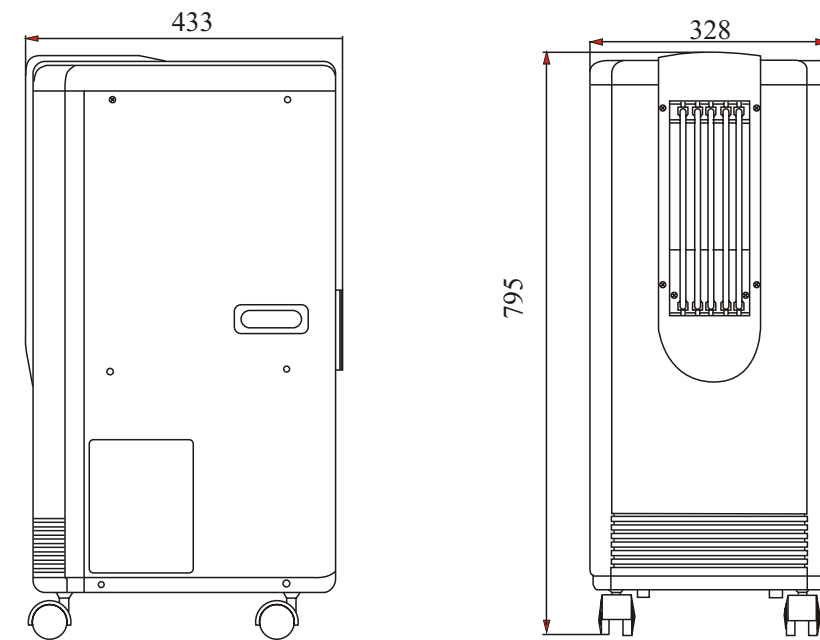
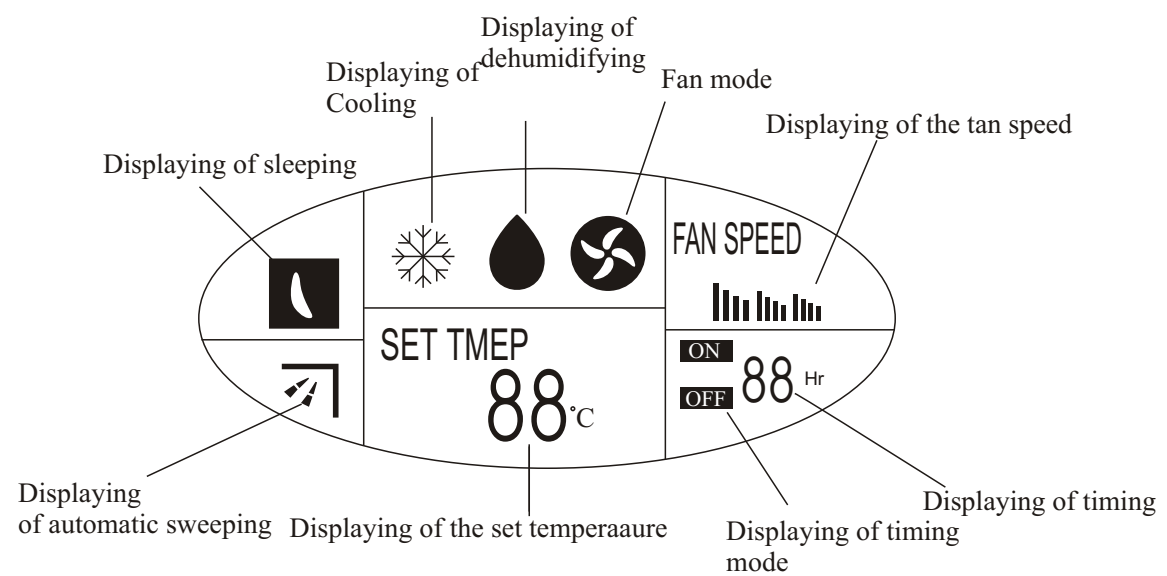



FUNCTION

1. Running Mode Key 

press the key to choose from three running mode:cooling mode:cooling→dehumidifying→Fan.The LCD window displays correspondingly:  →  → 



2. Fan Selection Key 

Press the key to choose from three fan speed:high→middle→low.The LCD window displays correspondingly:  →  → 

3. Sweep key: 

Press the key to enable automatic side-to-side sweeping of the indoor air.The LCD window displays ;press the key again to fix the indoor air at present direction.

4. Temperature Setting key 

Press the key to set the temperature between 10-30°C.Each press of the  part will increase the temperature for 1°C each press of the  part will decrease the temperature for 1°C.The temperature will be displayed in the LCD window.



5. Sleep Setting key 

Press the key to set or cancel Sleep Mode.When the LCD window displays  the air conditioner is under Sleep Mode.Press again to cancel the Sleep Mode,and the signal will disappear on the LCD window.

6. Power Switch key 

Power Switch on/off the power of the air conditioner.

7. Time Setting key: 

Press the key to set or cancel the Time Mode,or set time between 1-24hours.Each press of the  part will add one hour, which will be displayed on the LCD window, each pressing of the  part will reduce one hour, If it shows 1 hour.Press once to cancel the timing.

8. Water Full indicator of:

When the water tank is filled with water, the indicator will flash,and alarm with beep.The compressor stops working.The air conditioner enters fan mode.Please take out the water tank. Pour the condensed water, then replace it. The air conditioner runs as per the mode before stopping of the compressor(the compressor can only start after 3 minutes of time-delay protection).

9. The run indicator of the compressor:

In cooling or dehumidifying mode, the indicator will be on in the running of the compressor.

KNOCK-DOWN DRAWING AND LIST OF COMPONENT

机型: HM-07C03, HM-07C3/R1, HM-09CA03

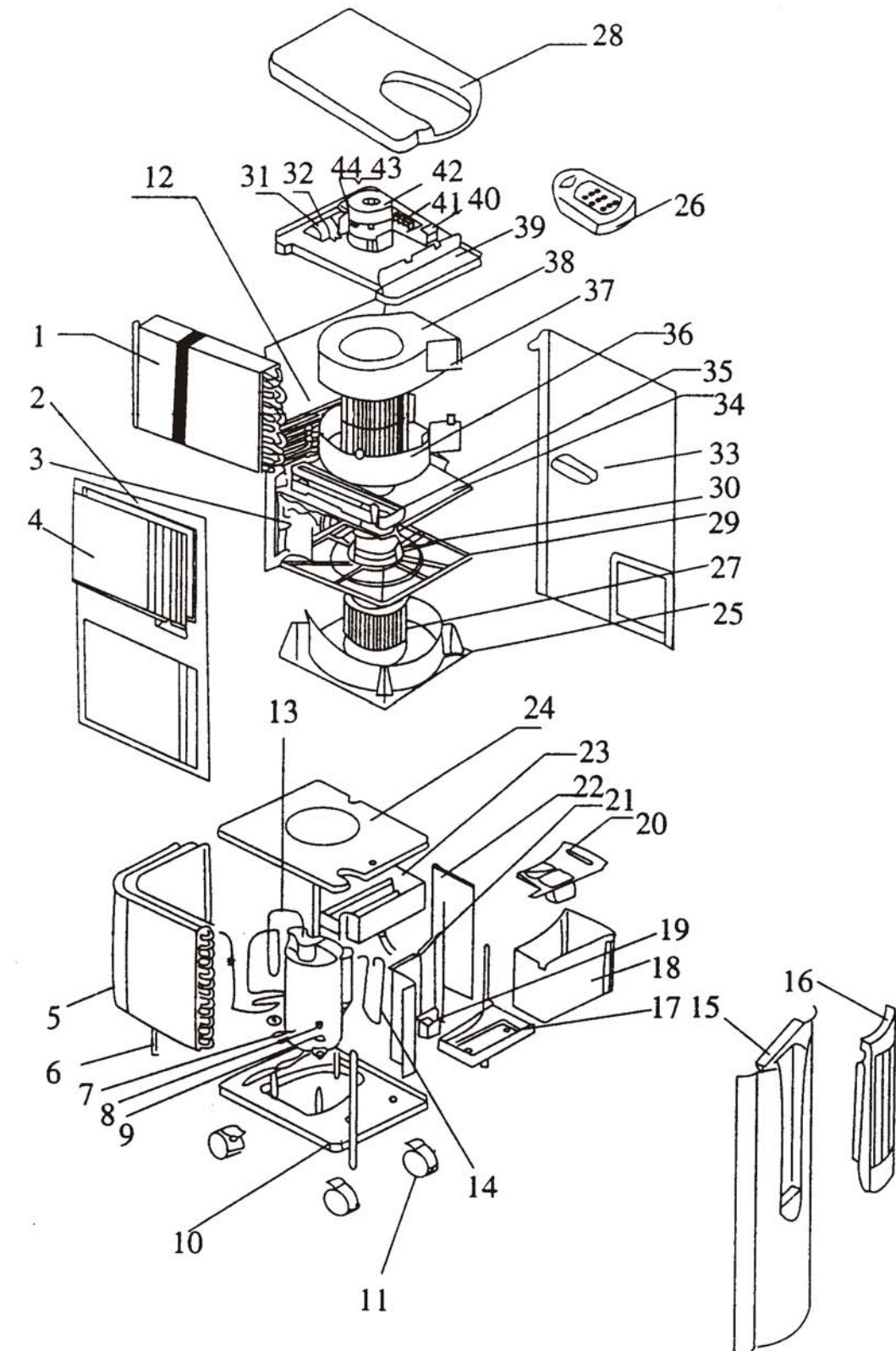

Model:HM-09CA03

N O.	Special NO.	Name	Quantity	description	Damageable parts(yes or no)	Cost price
1	0400080	Evaporator Assembly	1		No	
2	1231144	Side plate,left	1		No	
3	1301332	Draw board	2		No	
4	1231149	Indoor intake bar	1		No	
5	0400081	Condenser assembly	1		No	
6	1301331	Support bar	4		No	
7	2000119	Compressor	1		Yes	
8	5102034	Nut special	3		No	
9	1754742	Cushion rubber	3		No	
10	1101099	Bottom plate	1		No	
11	1431503	Wheel	4		No	
12	1231148	Rear panel	1		No	
13	2111740	Discharge pipe			No	
14	2111737	Suction pipe			No	
15	1231142	Front plate			No	
16	0100278	Front panel			No	
17	1431507	Storage tank base board			No	
18	1231145	Storage tank			No	
19	3400064	Micro switch			No	
20	1436506	Strong tank cover			No	
21	1101086	Partition plate assy			No	
22	1101088	Protective plate			No	
23	1231158	Drain pan			No	
24	1101089	Cover			No	
25	1231157	Vendiduct(outdoor)			No	
26	1231147	Cover panel			No	
27	1231160	Outside fan			No	
28	1231146	Cover			No	
29	1231153	Vendiduct cover(outdoor)			No	
30	3000079	Motor(down)			Yes	
31	3600142	Compressor capacitor			No	
32	1301330	Capacitor clamp			No	
33	1231145	Side plate right			No	
34	1301338	Support plate			No	
35	1436499	Drain pan			No	
36	1231152	Vendiduct (indoor,down)			No No	
37	1231159	Inside fan			No	
38	3800063	Vendiduct (indoor,up)			No No	
39	3300092	Electric board			No	
40	3000078 A	Tronsormer			No	
41	3600096	Control board			No	
42	3000078	Motor(up)			No	
43	3600096	Fan capacitor			Yes	
44	3600018 A	Motor capacitor			Yes	

Model:HM-07C03/R1

N O.	Special NO.	Name	Quantity	description	Damageable parts(yes or no)	Cost price
1	0400080	Evaporator Assembly	1		No	
2	1231144	Side plate,left	1		No	
3	1301332	Draw board	2		No	
4	1231149	Indoor intake bar	1		No	
5	0400081	Condenser assembly	1		No	
6	1301331	Support bar	4		No	
7	2000119	Compressor	1		Yes	
8	5102034	Nut special	3		No	
9	1754742	Cushion rubber	3		No	
10	1101099	chassis	1		No	
11	1431503	Wheel	4		No	
12	1231148	Rear panel	1		No	
13	2111740	Discharge pipe	1		No	
14	2111737	Suction pipe	1		No	
15	1231142	Front plate	1		No	
16	0100278	Front panel	1		No	
17	1431507	Storage tank base board	1		No	
18	1231145	Storage tank	1		No	
19	3400064	Micro switch	1		Yes	
20	1436506	Strong tank cover	1		No	
21	1101086	Partition plate assy	1		No	
22	1101088	Protective plate	1		No	
23	1231158	Drain pan	1		No	
24	1101089	Cover	1		No	
25	1231157	Vendiduct(outdoor)	1		No	
26	1231147	Cover panel	1		No	
27	1231160	Outside fan	1		No	
28	1231146	Cover	1		No	
29	1231153	Vendiduct cover(outdoor)	1		No	
30	3000079	Motor(down)	1		Yes	
31	3600142	Compressor capacitor	1		yse	
32	1301330	Capacitor clamp	1		No	
33	1231145	Side plate right	1		No	
34	1301338	Support plate	1		No	
35	1436499	Drain pan	1		No	
36	1231152	Vendiduct (indoor,down)	1		No No	
37	1231159	Inside fan	1		No	
38	3800063	Vendiduct (indoor,up)	1		No No	
39	3300092	Electric board	1		No	
40	3000078 A	Tronsormer	1		No	
41	3600096	Control board	1		No	
42	3000078	Motor(up)	1		No	
43	3600096	Fan capacitor	1		Yes	
44	3600018 A	Motor capacitor	1		Yes	

Exploded View

HSM—08C03 (Indoor unit)

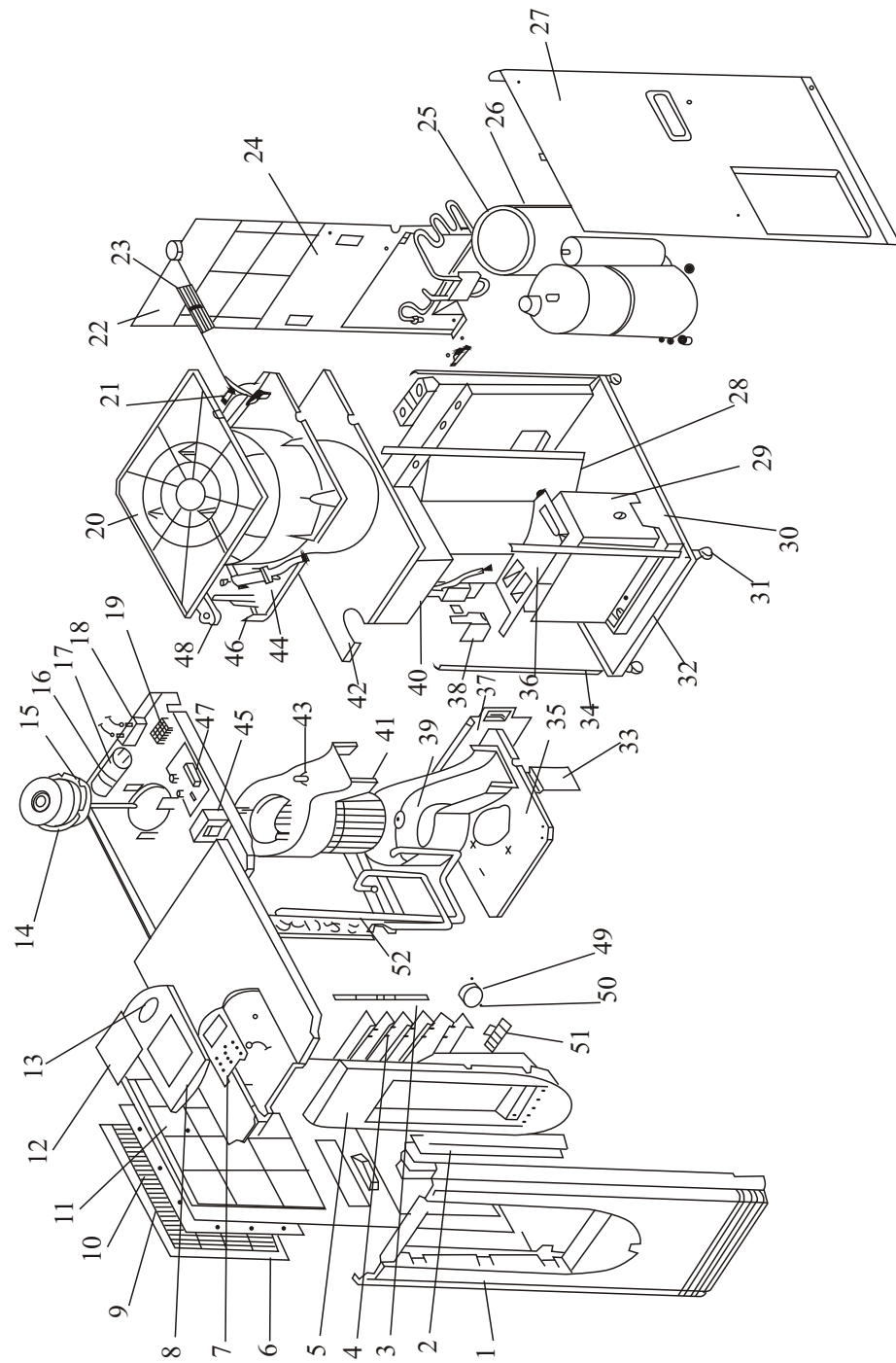

Model:HM-07C03/R1

N O.	Special NO.	Name	Quantity	description	Damageable parts(yes or no)	Cost price
1	1231142	Front panel	1		No	
2	1431496	verrical flap	1		No	
3	1431498	connection rod	2		No	
4	1436497	Horizontal flap	1		No	
5	1231143	Front panel inlay	1		No	
6	1231146	Top panel inlay	4		No	
7	3000092	Control panel	1		No	
8	1231146	Top panel	3		No	
9	1231149	Indoor intake bar	3		No	
10	1442517	filter	1		No	
11	1231144	Left side board	4		No	
12	1434516	Press key membrane	1		No	
13	1235168	Cover	1		No	
14	3000078	Upper motor	1		Yes	
15	1231154	electronic	1		No	
16	1301330	Capacitor clip	1		No	
17	3600142	Compressor motor	1		Yes	
18	2600141	Fan motor	1		Yes	
19	4000120	line contact bank	1		No	
20	1231153	scroll case cover (outdoor unit)	1		No	
21	1445520	Power cord clip	1		No	
22	1431738	Rear cover			No	
23	4200065	Power cord	1		Yes	
24	1431751	Connecting pipe bracker	1		No	
25	1762207	Sound absorbtion cushion	1		No	
26	2000110	copmpressor	1		Yes	
27	1231145	right side board	1		No	
28	1301926	Partition panel	1		No	
29	1231155	Water storage box	1		No	
30	1431507	Base board of Water storage box	1		No	
31	1431503	Foot whell	1		Yes	
32	1101090	chassis	1		No	
33	1301332	Pulling board	1		No	
34	1301331	Support bar	1		No	
35	1301338	baffle	1		No	
36	1436506	Water storage box xover	1		No	
37	1301476	Machine hanging board	1		No	
38	3400009	Full water switch	1		No	
39	1231152	Scroll cover(indoor unit)	1		No	
40	1231156	Cooled water box	1		No	
41	1231159	Fan(indoor unit)	1		Yes	
42	1101189A	cover	1		No	
43	1231151	Upper scroll cover (indoor unit)	1		No	
44	1445119	Water meeting pipe clip	1		No	
45	3800630	transformer	1		Yes	
46	1439445	Water meeting pipe	1		No	
47	3000092	Control panel	1		No	
48	1436449	Water meeting tray	1		No	
49	3000084	Synchronous motor	1		Yes	
50	1431550	Brace of Symchnotus motor	1		Yes	
51	1431513	flat board of flap	1		No	
52	0400080	condenser	1		Yes	

HSM—08C03 (Outdoor unit)

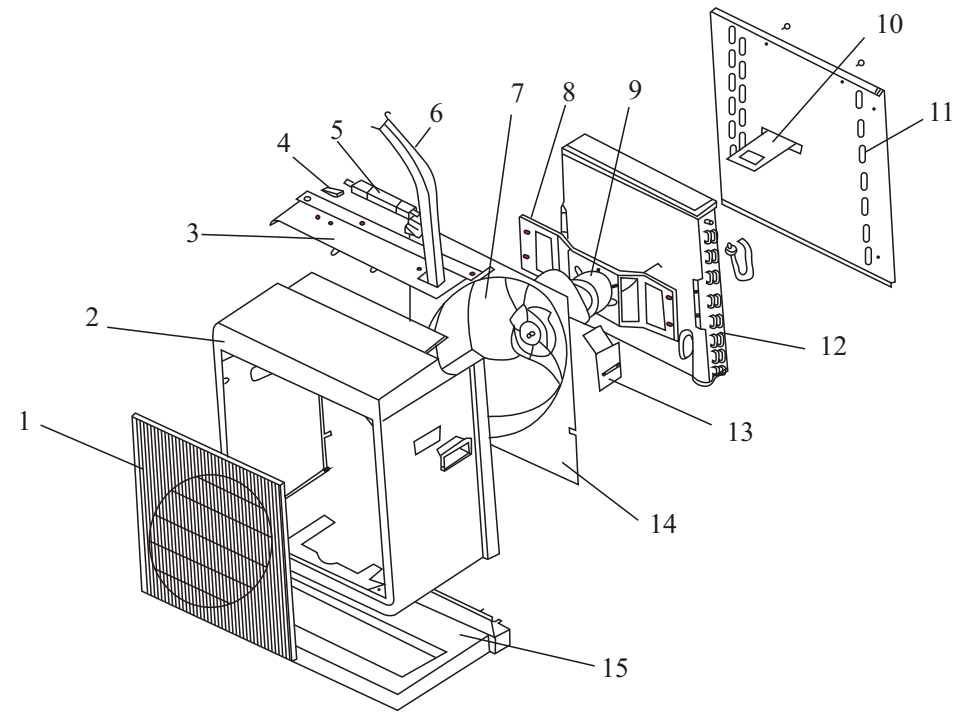

N O.	Special NO.	Name	Quantity	Description	Damageable parts(yes or no)
1	1436739	Inlet bars	1		No
2	1436730	Case	1		No
3	1436733	Handle holder	1		No
4	1436732	Handle abutment	1		No
5	1452737	Handle	1		No
6	0900092	Connecting pipe group	1		No
7	2336052	Axial fan	1		Yes
8	1301473	Motor holde	1		No
9	3000155	Outdoor fan	1		No
10	1101157	Connecting pipe baseboard	1		Yes
11	1301474	Side board	1		No
12	1436734	Condenser	1		No
13	1301474	Cord board	1		No
14	1436734	Wind circle	1		No
15	1436735	Outdoor chassis	1		No

THE FUNCTION OF ELECTRIC CONTROL CONTROL INTRODUCTION

Flow chart for operation

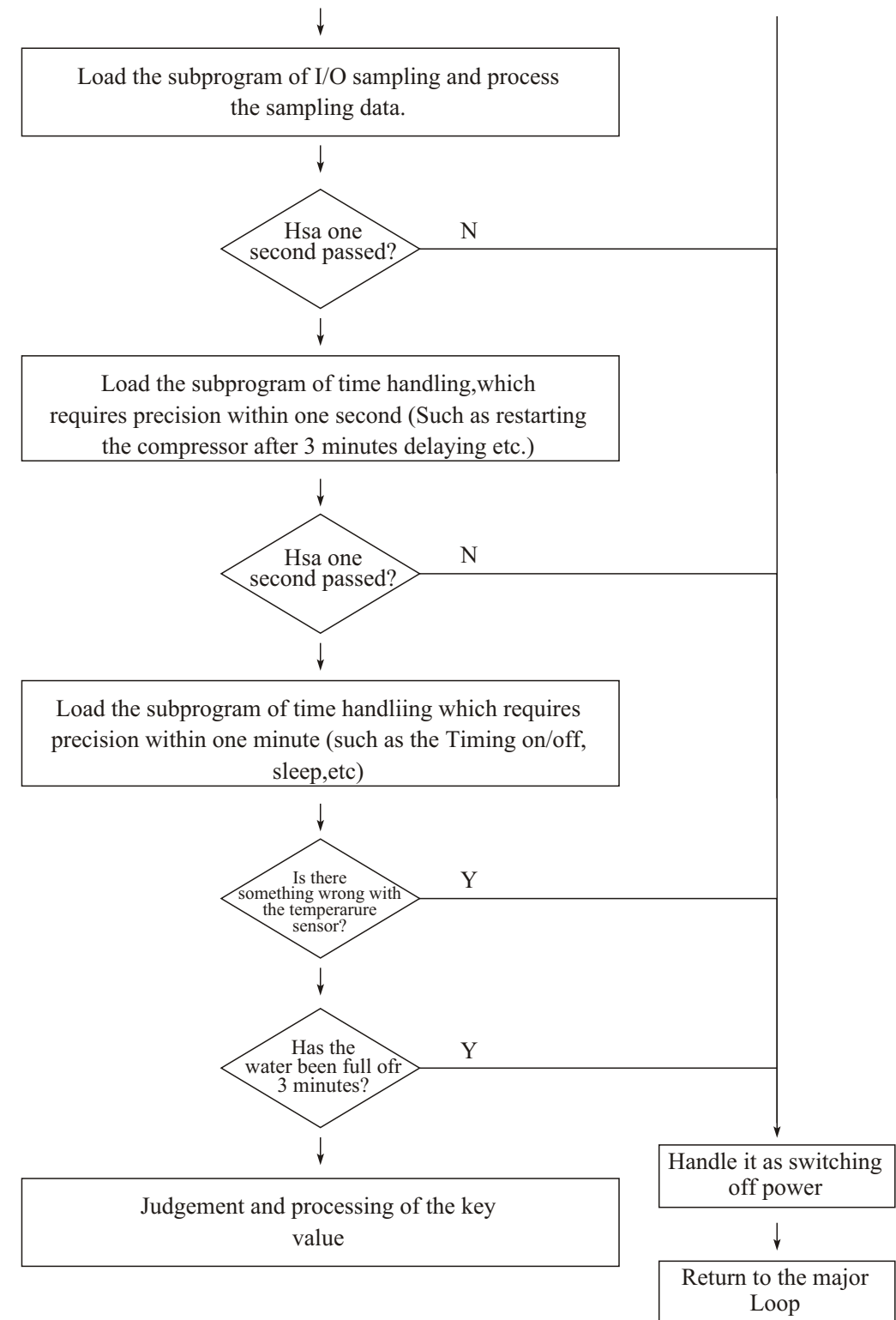
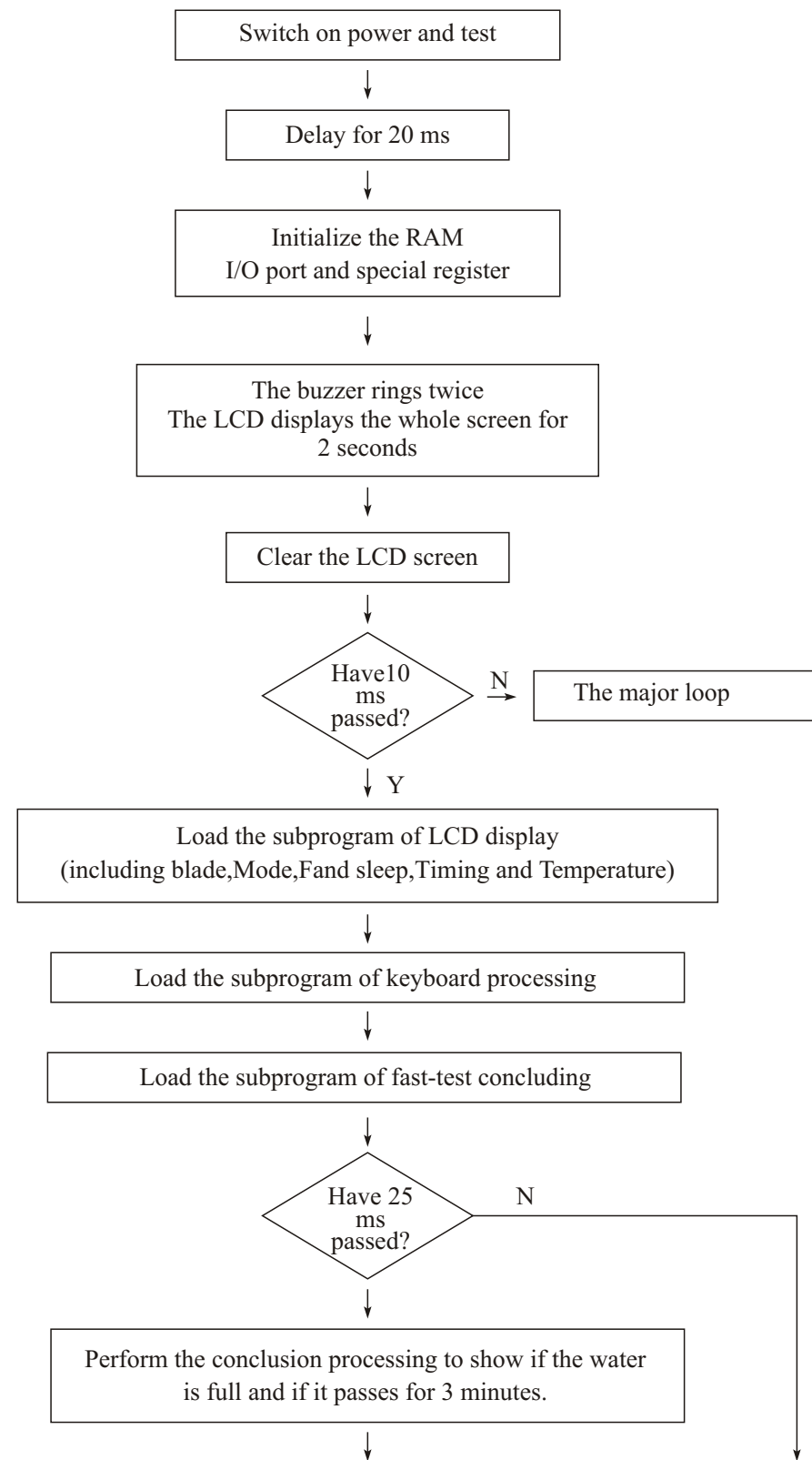

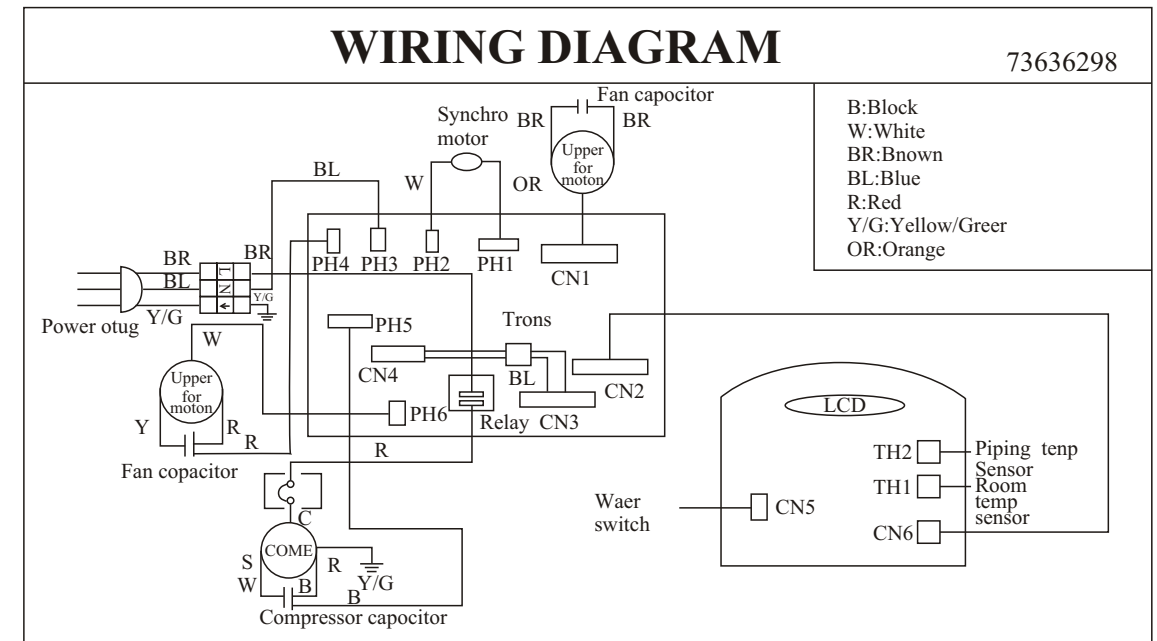
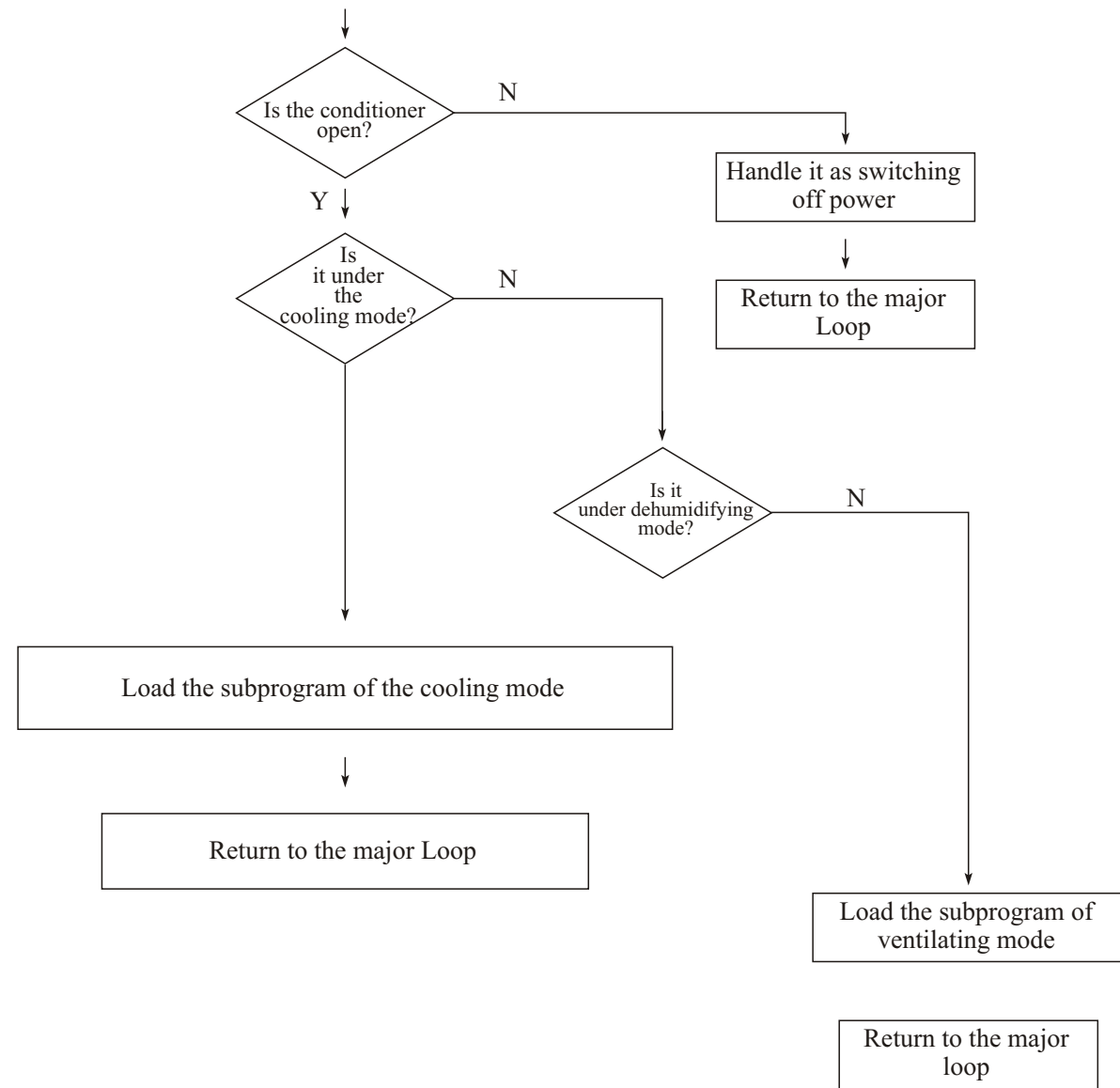

HM-07C03, HM-09CA03
 HM-07C03/R1, HM-07C04

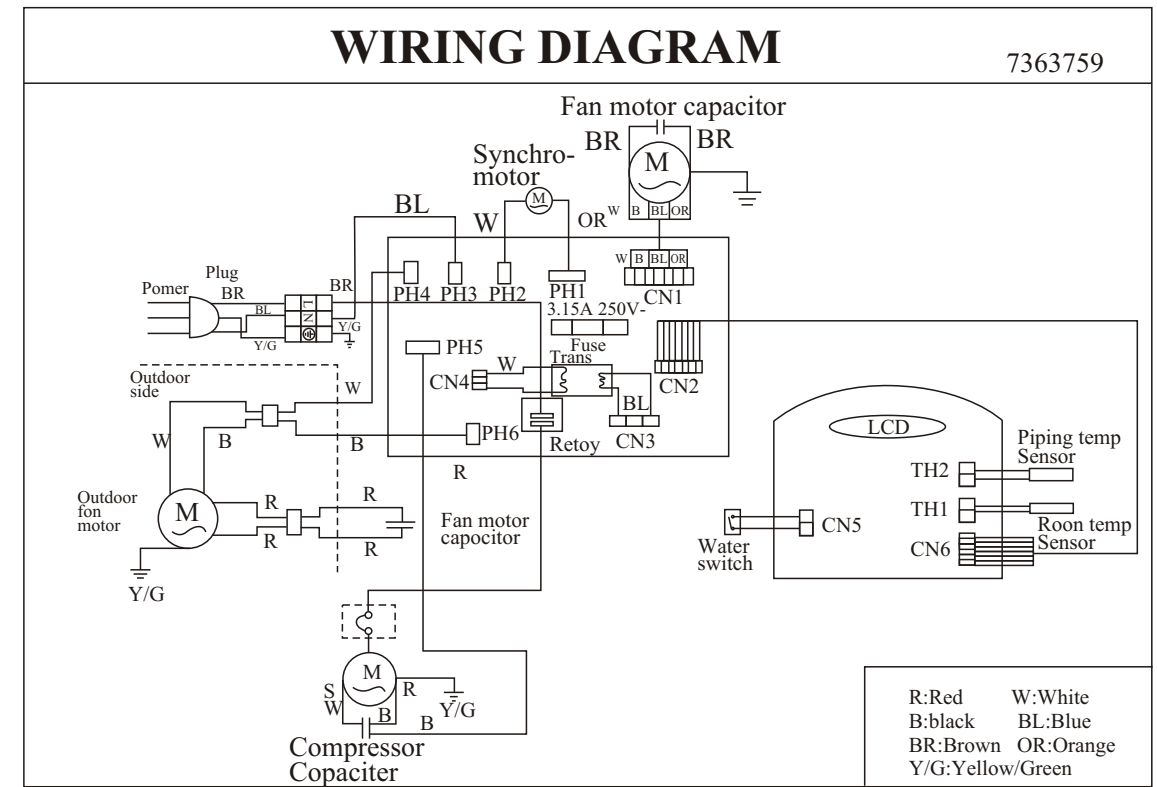

HM-08C03

9. Maintenance and trouble shooting

9.1. Maintenance manual

1) Functional instruction

1. Run mode: cooling → dehumidifying → air flowing

2. Fan adjusting: HI → MID → LO

3. Timing: Timing on 1-24 h

Timing on 1-24 h

4. The set temperature range: 15°C-30°C

5. Swing automatic swing or fix at a point

6. Sleep: 8 hours

2) Instruction of the run mode:

1) Cooling mode:

(1) The inner initialized set temperature is 24°C and the initialized fan is HI.

(2) The fan speed is adjustable, in turn of HI → MID → LO

(3) Adjusting of the temperature:

Each pressing of the “△” key will increase the set temperature for 1°C till it reaches 30°C, Each pressing of the “▽” key will decrease the set temperature for 1°C, till it reaches 15°C

(4) Adjusting of the air direction:

Under the mode of inner fan running, the air direction can be adjusted by the synchro motor to control the starting and closing of the motor

2) Dehumidifying mode:

(1) The fan speed is not adjustable

In case of the ambient temperature > 15°C, the fan speed is LO and compressor is open;

In case of 12°C ≤ ambient temperature ≤ 15°C, the fan speed is MID, the Compressor is open;

(2) The air direction is adjustable.

(3) The set temperature is not adjustable.

3) Air supply mode:

(1) Water full protection

Under any mode, when the water full protection is detected to be activated, the buzzer will beep several times consecutively, and the water full alarm lamp will flash on and off with a 0.5 second frequency. The compressor and outer fan will stop running. It will enter air supply mode. The inner fan will run at the former speed. If the water full protection is released in 3 minutes, the controller will run under previous set mode and the water full alarm lamp will be off. If it is not released in 3 minutes, the inner fan will stop running either and whole machine is under stand-by mode. But the water full alarm lamp will keep on flashing till it is released.

2) Protection against freezing

When the coil pipe temperature sensor detects that the surface temperature of the evaporator $T \leq -2^\circ\text{C}$, the compressor and the fan will stop running, the inner fan will run at HI speed and the Fan key will be impotent. When the detected temperature > -8°C and the stop time of the compressor is longer than 3 minutes, the compressor and the outer fan will be started and the inner fan runs at set fan speed.

3) Protection of the compressor

The compressor must be restarted after 3 minutes from the former stop, except for the power failure.

5) Sleep protection

1. The function is only activated under cooling mode, and impotent under other modes.

2. After one hour running under cooling sleep, the set temperature will rise for 1°C, and rise for another 1°C after one another hour, after another 6 hours of running the complete machine will be shut down.

3. In case that Sleep and Timing Off are set at the same time, the first impotent not will be activated.

4. In Sleep mode the Timing On will be impotent.

6) Timing function

1. The timing Off can be set when the machine is running; the Timing On can be set when the machine is shut down.

2. The timing range is 1-24h;

Each pressing of the “△” key will raise the set time for 1h; each pressing of the “▽” key will reduce the set time for 1h. When it is added to 24h the “△” key or “▽” key will cancel the timing.

9.2 Trouble shooting

No.	Phenomenon	Reason	Remedy
1	The complete machine does not start without any reflection after the power is switched on	<input type="checkbox"/> No power supply or abnormal power supply <input type="checkbox"/> The fuse is broken <input type="checkbox"/> The corrugated copper plate is burnt <input type="checkbox"/> The L end and compressor end of the compressor relay are mixed up <input type="checkbox"/> The plug between the high electrode and the weak electrode, or between the transformer and transformer and the circuit board is loose.	<ul style="list-style-type: none"> ● Check if the power line and plugs are well ● Replace the fuse ● Check out the reason of burning, and welding the copper plate after debugging ● Change the terminals ● Insert the plug firmly
2	The LCD displays, but the complete machine can not start.	<input type="checkbox"/> The indoor temperature sensor pack is with open circuit <input type="checkbox"/> The water tank is full of the water level switch is with short circuit	<ul style="list-style-type: none"> ● Check the circuit of the temperature sensor pack ● Discharge the water or check the circuit of the water level switch.
3	The refrigerating works with bad effect	<input type="checkbox"/> The refrigerating medium is leaking. <input type="checkbox"/> The refrigerating system is blocked. <input type="checkbox"/> The compressor is broken down. <input type="checkbox"/> The air circulation is bad <input type="checkbox"/> The fan setting is not reasonable.	<ul style="list-style-type: none"> ● Detect the leakage and fill the refrigerating medium. ● Clean the pipeline system. and fill again. ● Replace the compressor. ● Clean the filter screen. ● Set reasonable fan speed.
4	The noise is large.	<input type="checkbox"/> The components are loosen. <input type="checkbox"/> The fan is off-center. <input type="checkbox"/> The compressor is broken down.	<ul style="list-style-type: none"> ● Find out the loosen part and fasten it ● Replace the fan ● Replace the compressor.
5	The machine does not stop after the water is full	The water level switch is with open circuit.	Check and repair the water level switch circuit.
6	The sweep fins do not move or move abnormally.	<input type="checkbox"/> The connector of the sweep motor is loosen. <input type="checkbox"/> The spot weld of the sweep motor is with rosin joint. <input type="checkbox"/> The sweep motor is broken down. <input type="checkbox"/> There's mechanical resistance with the sweep mechanism.	<ul style="list-style-type: none"> ● Repair or replace the connector. ● Weld the spot to be under good condition. ● Replace the sweep motor. ● Repair or replace the sweep spindle, pitman, pins.
7	The LCD is not complete or not clear	<input type="checkbox"/> The LCD foot is with rosin joint <input type="checkbox"/> The LCD is broken down.	<ul style="list-style-type: none"> ● Check the spot weld. ● Replace the LCD or major control board.

10、SYSTEM FLOW CHART

(1) Refrigerant using:

HM-07C03 uses freon R22 as its refrigerant, when leaving factory, refrigerant charge is 0.52 g.

HM-07C03 / R1 uses freon R407C as its refrigerant, when leaving factory, refrigerant charge is 0.52 g.

HM-09CA03 uses freon R22 as its refrigerant, when leaving factory, refrigerant charge is 0.6 g.

HSM-08C03 uses freon R22 as its refrigerant, when leaving factory, refrigerant charge is 0.75 g.

(2) system vacuumize:

After whole set of mobile air conditioner assembling is finished,, use vacuum pump to draw out air and water in the indoor unit. System vacuum tolerance will be under 200Pa.

(3) Diagram of pipe system:

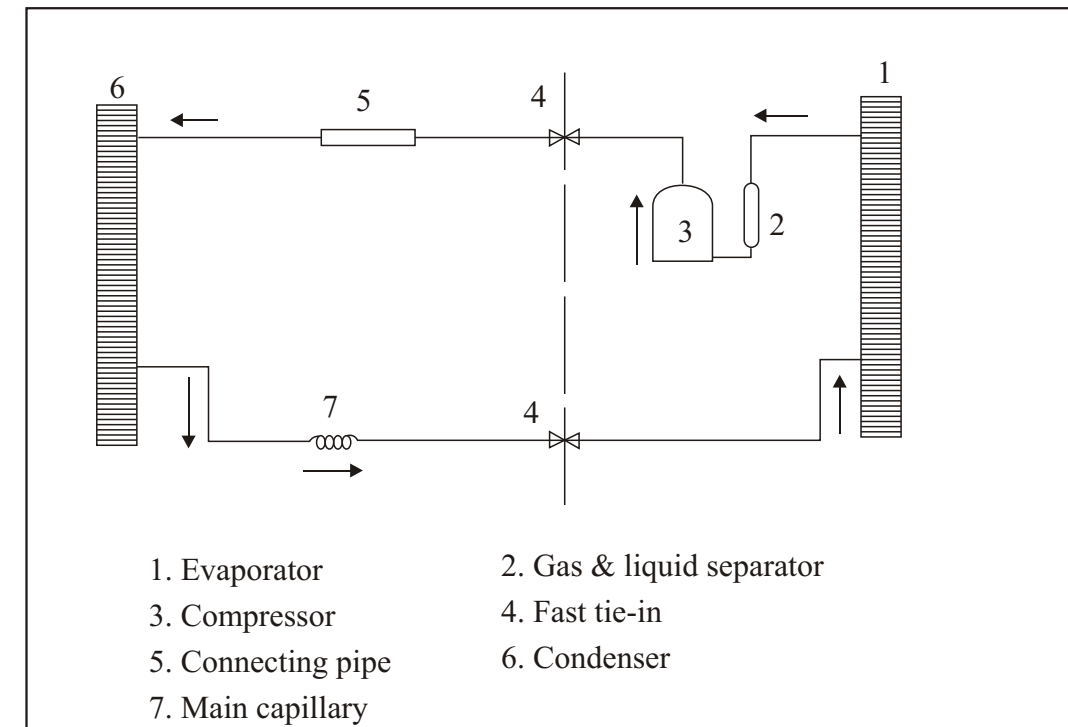

(4) type of compressor and compressor feature:

INSTALLATION AND REPAIRING

In order to make the air conditioner to work effectively, first need to calculate the cooling capacity of the air conditioner, according to the room size and surroundings. After selecting a proper one and putting it in a suitable work place, please confirm the place to install the air conditioner referring to the following instruction:

1. Better install the outdoor unit in the outdoors to make an easy heat exchange. The ideal place: out of window, balcony, corridor and so on. To make the outdoor have an easy heat exchange, please leave the distance between the back of outdoor unit and the wall or other things no less than 5CM. (Fig.1)
The specific installation process refers to installation.

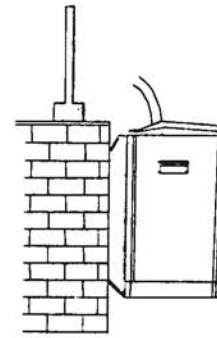

Fig. 1

NOTE:

The bracket to support the outdoor unit should be strong and firm, and endure the pressure of the unit. Regularly check the bracket about its firm condition and rusted degree to avoid accidents.
Only using the connecting pipe to hang the outdoor unit is definitely forbidden.

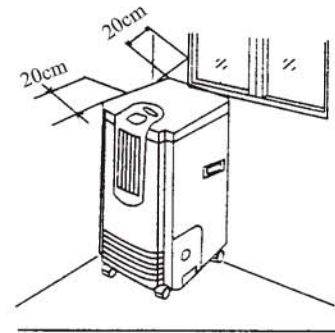

Fig. 2

2. The left side of indoor unit should leave the objects (such as curtain, wall, etc) no less than 20CM. To guarantee smooth ventilation the alien things should not block outlet. (Fig.2)

3. The connecting pipe can cross the chink of the window. When the unit in operation, the window should be closed as tight as possible to avoid the loss of energy. (Fig.3)

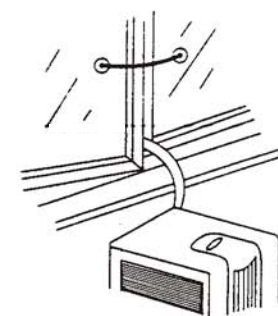

Fig. 3

4. If you want to close the window tight, you can cut a 55×25mm² hole in the window frame, the location of the hole can be decided according to concrete condition. After the connecting pipe crossing the window, sealing glue should be used to avoid entering of water. (Fig.4)

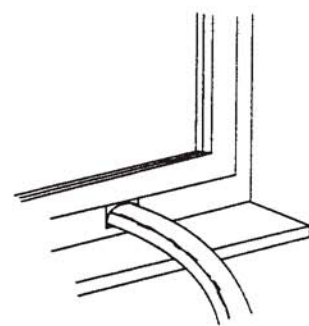
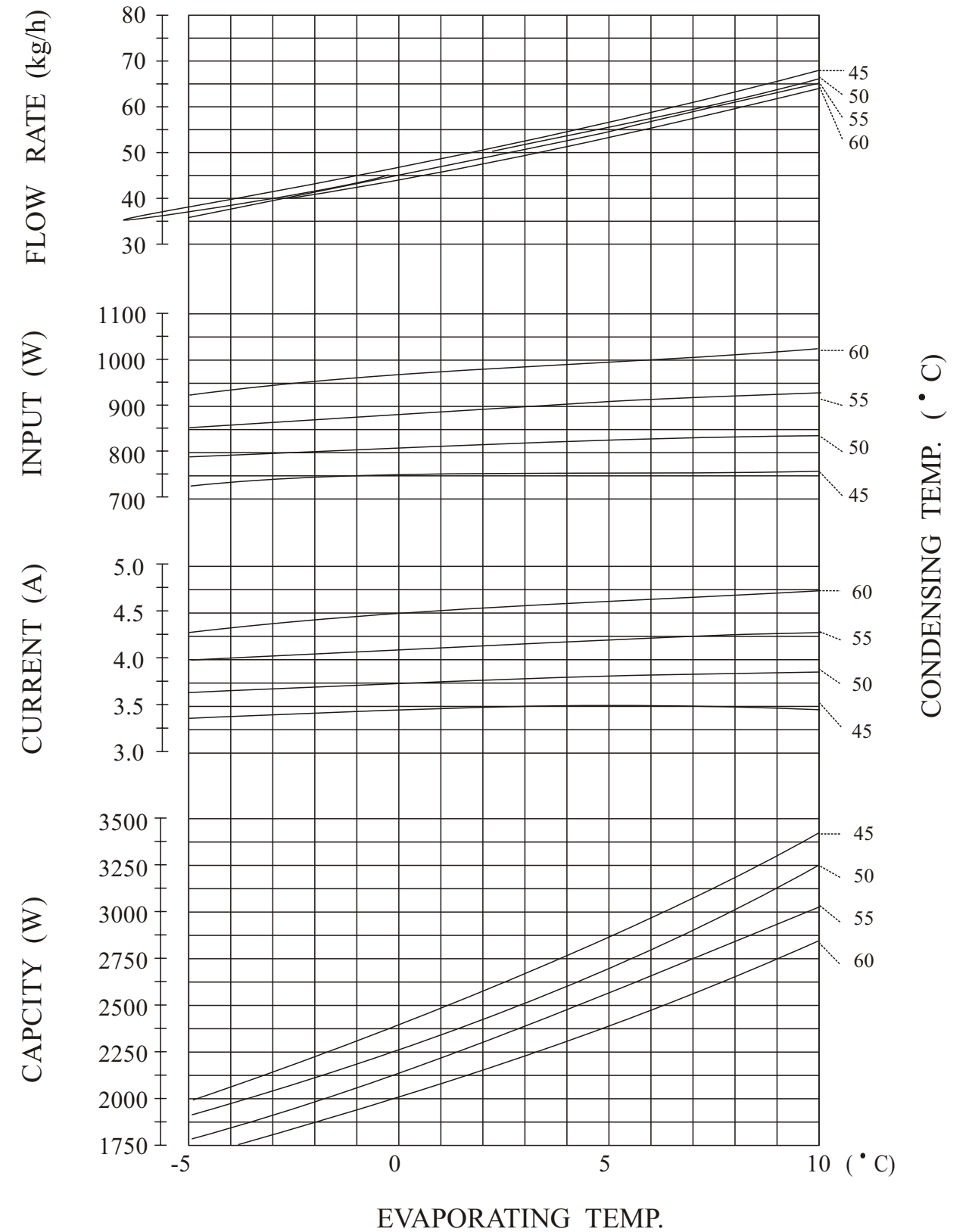

Fig. 4

PERFORMANCE CURVE

220V-- 50Hz-- 1PHASE
SUCTION GAS TEMP.-- 35 (°C)
UNDER COOL ----- 8.3 (°K)
AMBIENT TEMP.----- 35 (°C)
RUNNING CAPACITOR--25MFD



PERFORMANCE CURVE

220V-- 50Hz-- 1PHASE
 SUCTION GAS TEMP.-- 35 (°C)
 UNDER COOL ----- 8.3 (°K)
 AMBIENT TEMP.----- 35 (°C)
 RUNNING CAPACITOR--25MFD

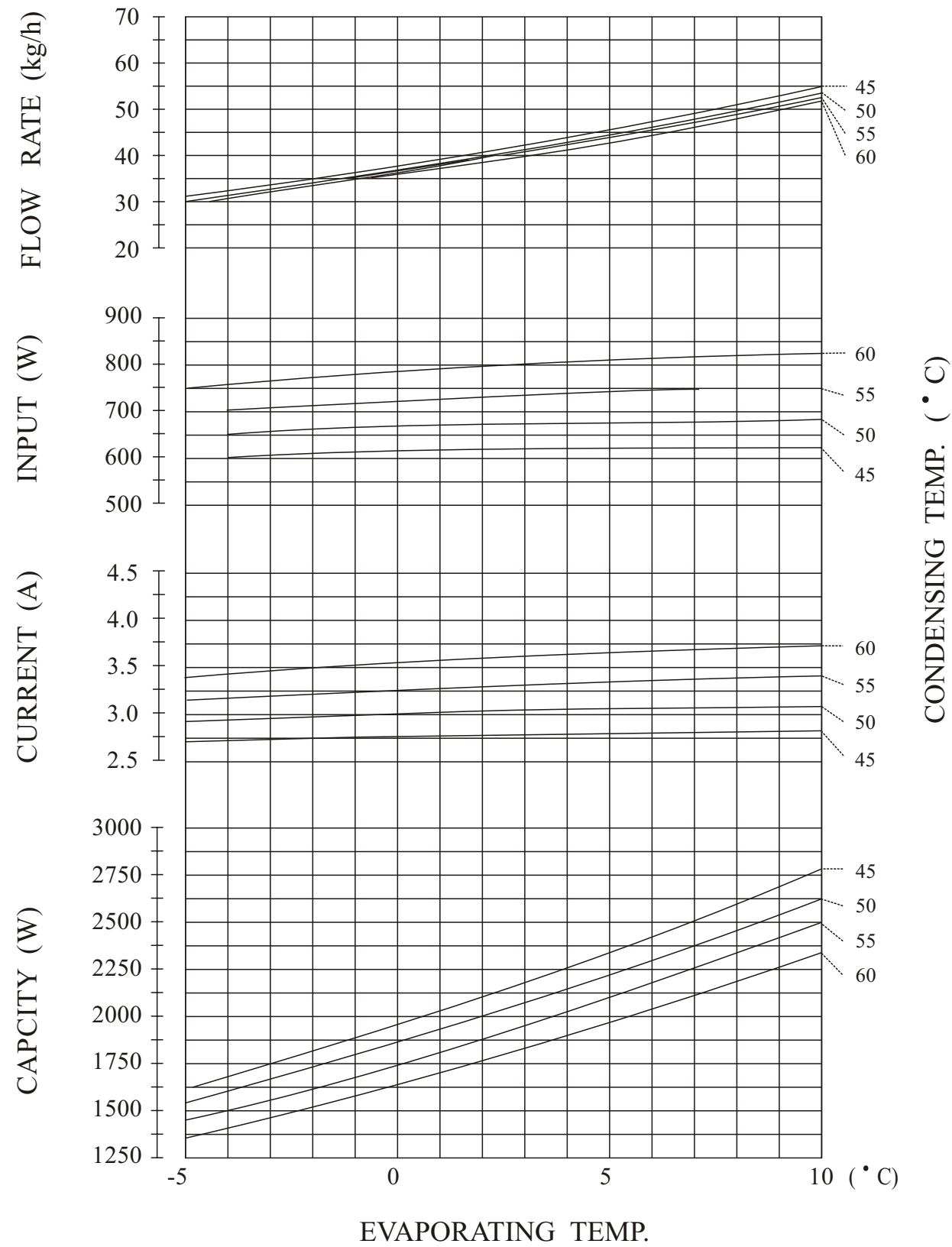

PERFORMANCE CURVE

220V-- 50Hz-- 1PHASE
 SUCTION GAS TEMP.-- 35 (°C)
 UNDER COOL ----- 8.3 (°K)
 AMBIENT TEMP.----- 35 (°C)
 RUNNING CAPACITOR--25MFD

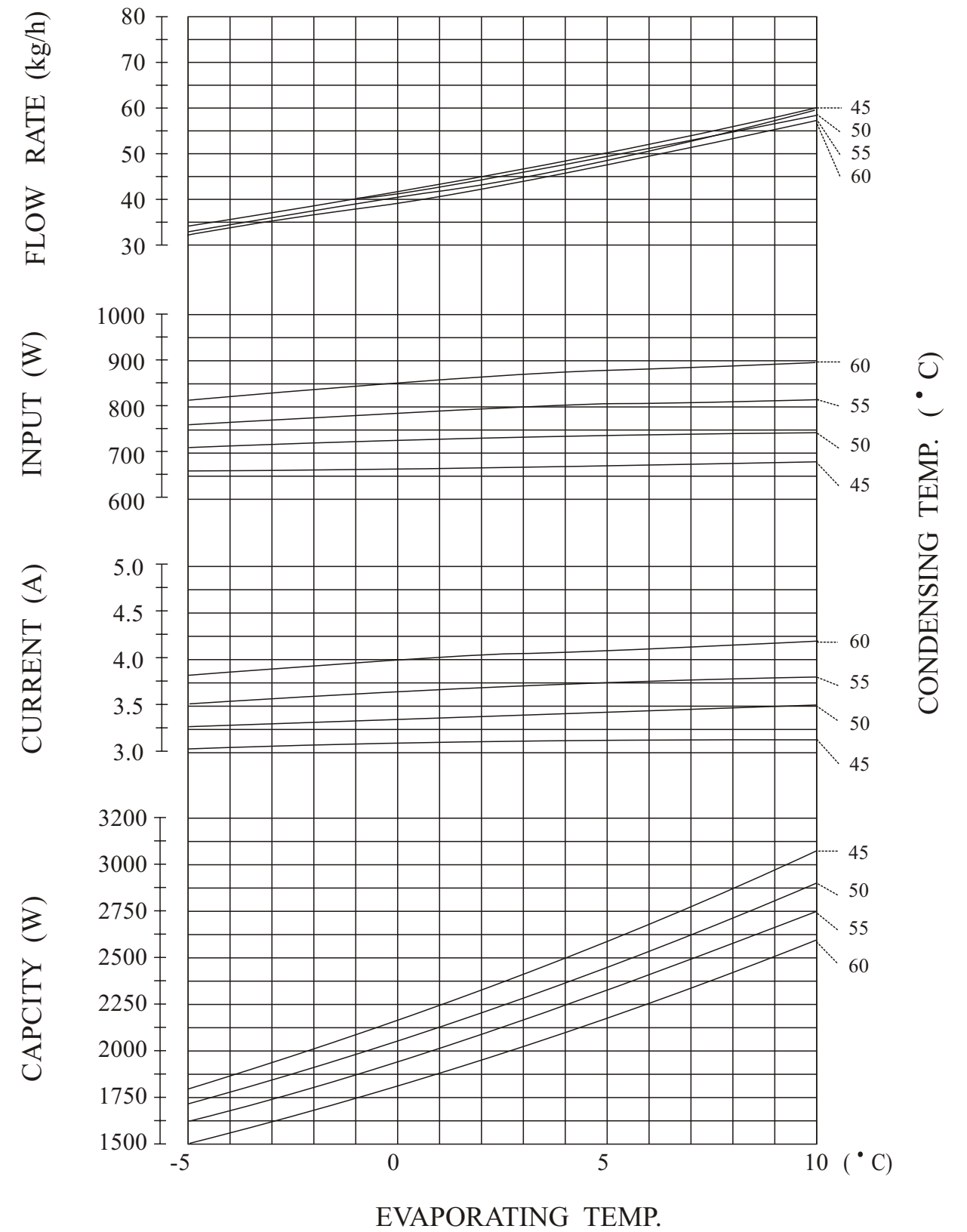

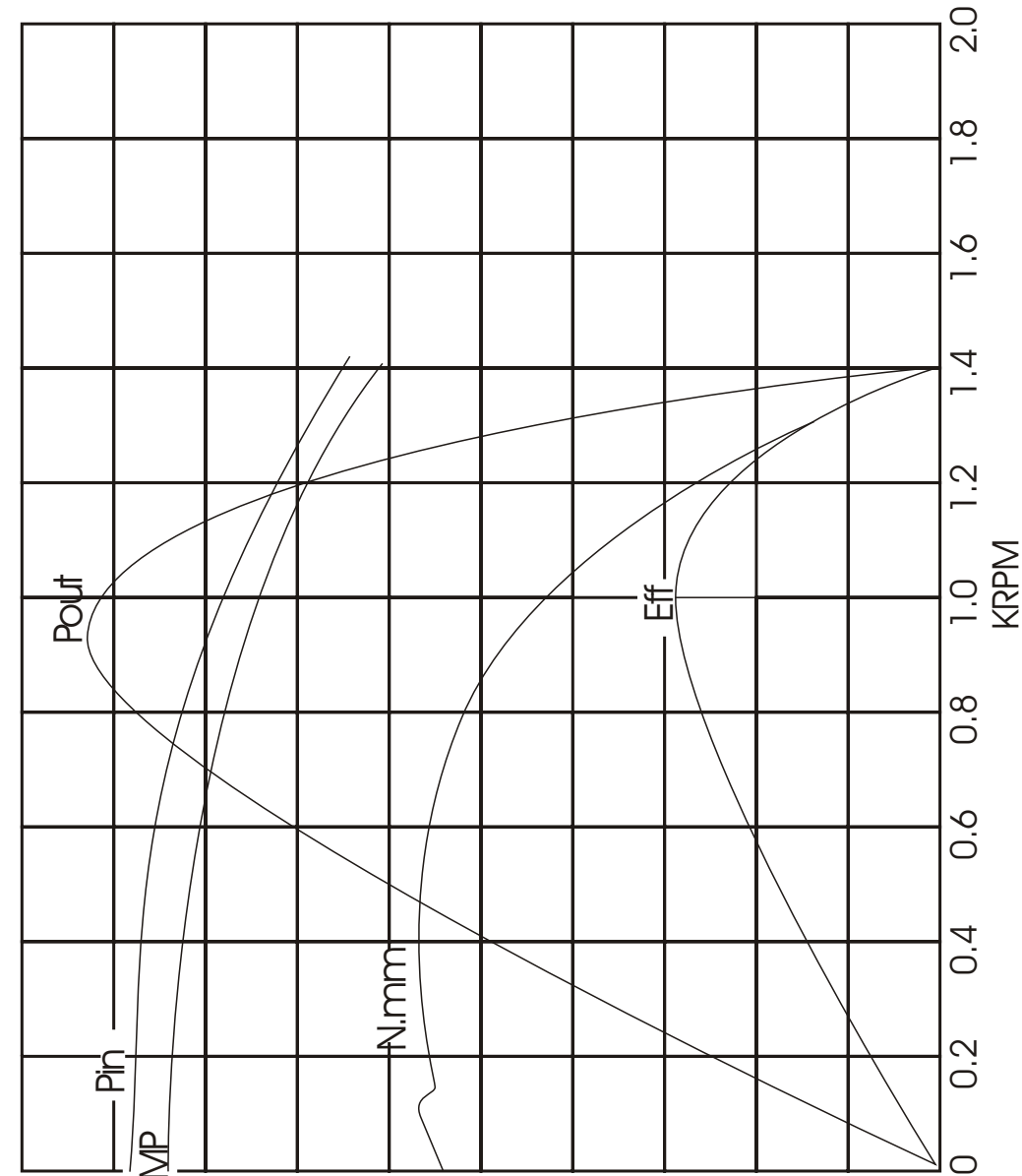

EFF	AMP	Pin	Pout	Nimm
0.9	.18	36	9.0	180
0.8	.16	32	8.0	160
0.7	.14	28	7.0	140
0.6	.12	24	6.0	120
0.5	.10	20	5.0	100
0.4	.08	16	4.0	80
0.3	.06	12	3.0	60
0.2	.04	8	2.0	40
0.1	.02	4	1.0	20
0.0	.00	0	0.0	0

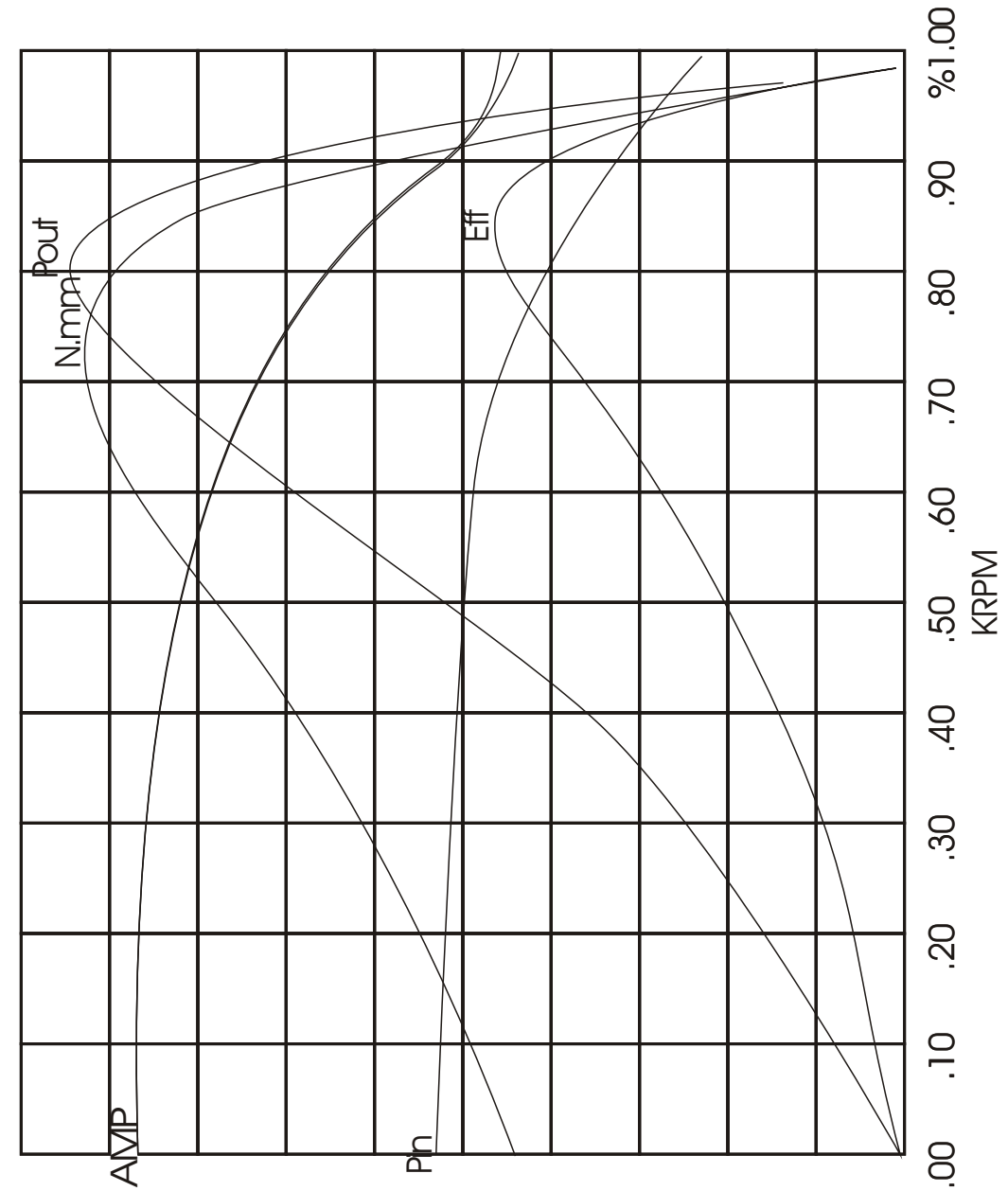

Pin	AMP	EFF	Pout	Nimm
180	.54	0.9	36	450
160	.48	0.8	32	400
140	.42	0.7	28	350
120	.36	0.6	24	300
100	.30	0.5	20	250
80	.24	0.4	16	200
60	.18	0.3	12	150
40	.12	0.2	8	100
20	.06	0.1	4	50
0	.00	0.0	0	0

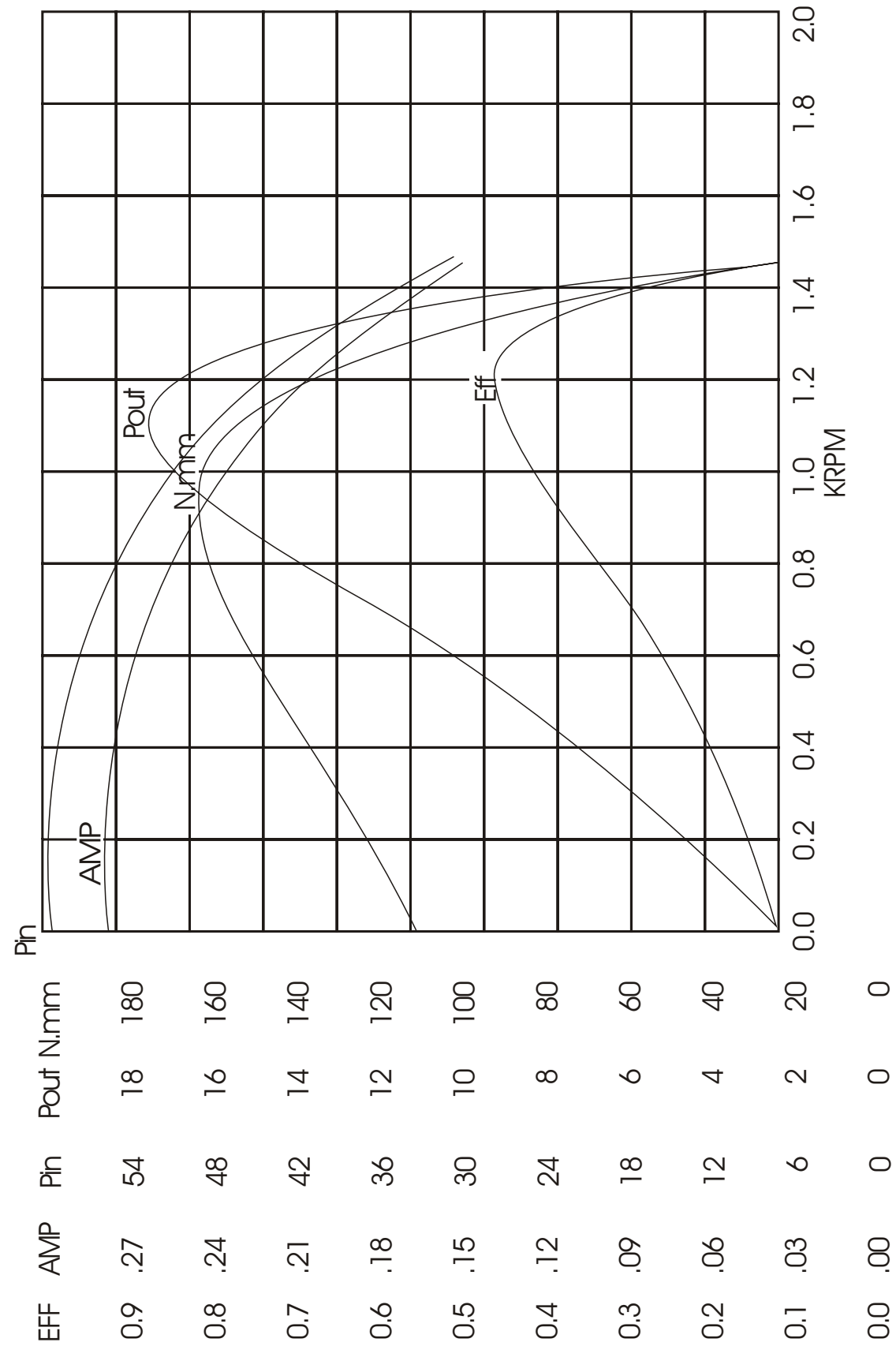

8. List of main material for PCB

8.1 Main PCB

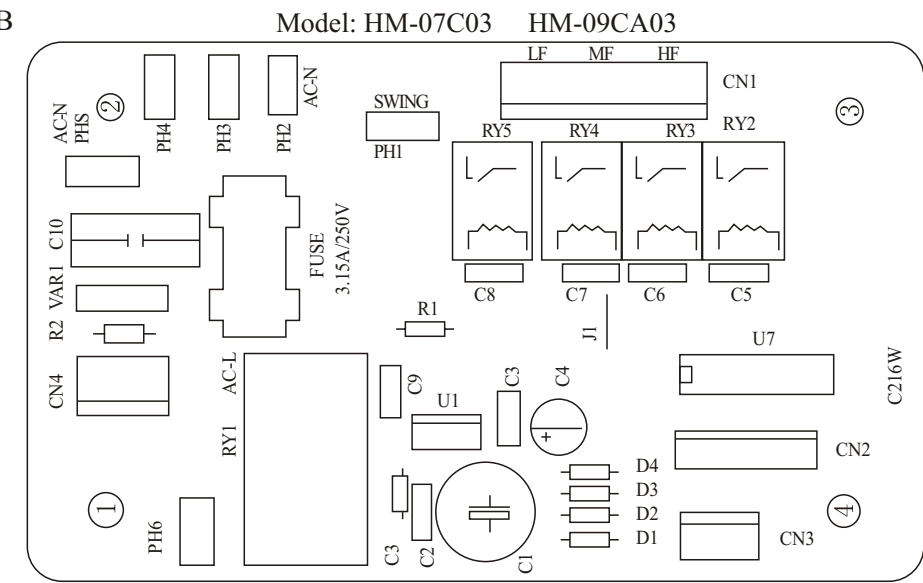

No.	Name	Model&Spec.	Single machine
1	Carbon-film resistor	47 Ω 1/4W	1
2	Carbon-film resistor	100 Ω 1/4W	3
3	Carbon-film resistor	510 Ω 1/4W	2
4	Carbon-film resistor	1K 1/4W	3
5	Carbon-film resistor	10K 1/4W	3
6	Carbon-film resistor	100K 1/4W	3
7	Carbon-film resistor	1M 1/4W	1
8	Precision resistance	4.3K 1/4W	2
9	Exclusion	A103 10K 5P	1
10	Electrolytic capacitor	47 μ F/16V	1
11	Electrolytic capacitor	100 μ F/16V	1
12	Electrolytic capacitor	470 μ F/16V	1
13	Electrolytic capacitor	1000 μ F/25V	1
14	Ceramic capacitor	104	18
15	Ceramic capacitor	30P	2
16	Diode	IN4148	1
17	Diode	IN4001	4
18	Triode	9013EBC	1
19	Voltage-regulator diode	3V	1
20	Light-emitting diode	φ 3 Red, green	1 each
21	Crystal oscillator	4.19MHz	1
22	Integrated package	7805	1
23	IC	uPD75P3036	1
24	IC	2003	1
25	Inductance	330 μ H	2
26	Buzzer	HDK	1
27	Piezoresistor	500NR-10D	
28	High-voltage capacitor	0.1 μ F250V	
29	Protective tube	3.15A/250V	
30	Protective tube seat		
31	Pin	6.3X0.8	
32	Needle file	VH-7	
33	Needle file	XH-7	

8. List of main material for PCB

8.2 PCB of panel

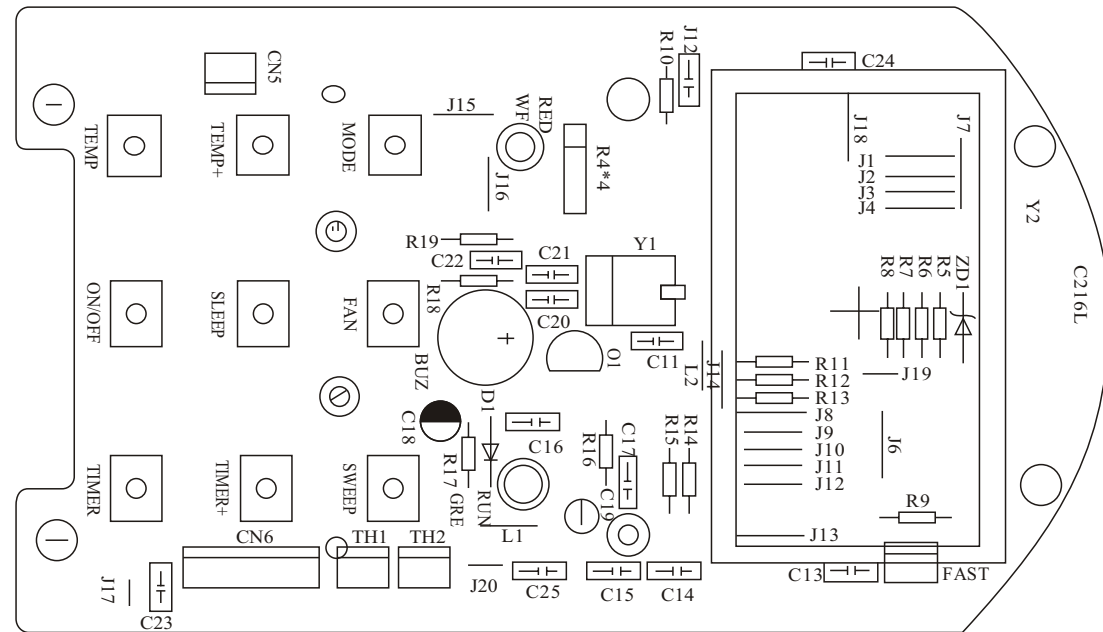

No.	Name	Model&Spec.	Single machine	Remarks
1	Carbon-film resistor	100 Ω 1/4W ±5%	1	
2	Carbon-film resistor	200 Ω 1/4W ±5%	3	
3	Carbon-film resistor	510 Ω 1/4W ±5%	2	
4	Carbon-film resistor	1K 1/4W ±5%	3	
5	Carbon-film resistor	10K 1/4W ±5%	3	
6	Carbon-film resistor	100K 1/4W ±5%	3	
7	Carbon-film resistor	1M 1/4W ±5%	1	
8	Precision resistance	4.3K 1/4W ±5%	2	
9	Exclusion	A103 10K 5P	1	
10	Electrolytic capacitor	47 μ F/16V	1	
11	Electrolytic capacitor	100 μ F/16V	1	
12	Electrolytic capacitor	470 μ F/16V	1	
13	Electrolytic capacitor	1000 μ F/25V	1	
14	Ceramic capacitor	104 ±20%	18	
15	Ceramic capacitor	30P ±20%	2	
16	Diode	IN4148	1	
17	Diode	IN4001	4	
18	Triode	9013EBC	1	
19	Voltage-regulator diode	3V	1	
20	Light-emitting diode	φ 3 Red, green	1 each	
21	Crystal oscillator	4.19MHz	1	
22	Integrated package	7805	1	
23	IC	uPD75P3036	1	
24	IC	2003	1	
25	Inductance	330 μ H	2	
26	Buzzer	HDK	1	
27	Piezoresistor	500NR-10D	1	Heatshrinkable tube

8. List of main material for PCB

8.2 PCB of panel

No.	Name	Model&Spec.	Single machine	Remarks
28	High-voltage capacitor	0.1 μ F250V	1	Sheathing
29	Protective tube	3.15A/250V	1	
30	Protective tube seat		2	
31	Pin	6.3X0.8	6	
32	Needle file	VH-7	1	
33	Needle file	XH-7	1	
34	Needle file	XH-3	1	
35	Needle file	VH-3	1	
36	Needle file	S-EH-2	3	
37	Needle file	S-EH-7	1	
38	Needle file	S-XH-2	1	Row needle
39	Press key	6×6×5mm	9	
40	Relay	AJM12113	1	
41	Relay	OJE-SH-112DM	4	
42	LCD		1	
43	PCB	C216L	1	
44	PCB	C226W	1	
45	Temperature response head	Length of the glass tube 55cm	1	φ 4 sheathing, heat-shrinkable tube
46	Temperature response head	Length of the copper tube 68cm	11	φ 4 sheathing
47	Wire bundle	YD-7	21	
48	Jumper	10mm	1	
49	Jumper	5mm	1	

Sincere Forever



Haier Group

Tel :86-532-8938356

Web site : <http://www.haier.com>



Большая библиотека технической документации

<https://splitsystema48.ru/instrukcii-po-ekspluatacii-kondicionerov.html>

каталоги, инструкции, сервисные мануалы, схемы.